

Reguero Baterias.es 91-7973512

5 OPzS 350



Specification	
Float Charge	U = 2.23 V/cell ± 1%, between 10°C and 30°C $\Delta U/\Delta T = -0.004$ V/K below 10°C in the monthly average
Boost Charge	U = 2.35 to 2.40 V/cell, time limited
Dimension	Length 124 mm Width 206 mm Height 536 mm
Weight	Dry: 20 kg Wet: 29 kg
Self Discharge	Approx. 2% per month at 20°C
Positive Electrode	Tubular plate with low antimony alloy (< 2 %)
Negative Electrode	Flat with long life expander active material
Separation	Microporous separator
Electrolyte	Sulphuric acid of 1.24 kg/l at 20°C
Container	High impact, transparent SAN
Lid	ABS (SAN)* in grey color
Blocks with Blind Cells	4V, 6V, 8V, 10V
Plugs	Ceramic plugs according to DIN 40740
Pole Sealing	100 % gas-and electrolytetight, sliding-pole
Connector	Flexible insulated copper cable with cross-section of 35, 50, 70, 95 or 120 mm ² (35, 50 or 70 mm ²)*
Kind of Protection	IP 25 regarding DIN 40050, touch protected according VBG 4
Reference Temperature	20°C at C10 (1.80 V/cell) and 25°C at C100 (1.85 V/cell)
Initial Capacity	100%
Depth of Discharge	Normally up to 80% More than 80% DOD or discharges beyond final discharge voltages (dependent on discharge current) have to be avoided

Constant Current Discharge (Amperes) at 20°C (68°F)

F.V/Time	15min	30min	1h	2h	3h	4h	5h	6h	8h	10h	20h
1.90V/cell	130.0	126.0	113.3	83.2	67.4	55.8	49.5	44.4	37.1	32.4	19.3
1.87V/cell	177.2	161.3	130.8	96.3	76.5	63.6	55.8	48.6	40.7	34.4	19.6
1.83V/cell	220.5	193.0	153.1	108.2	85.2	70.1	61.0	53.1	43.9	36.8	20.8
1.80V/cell	251.1	215.7	166.6	115.3	89.9	74.1	64.0	55.4	45.3	38.0	21.2
1.75V/cell	297.2	244.1	183.2	123.5	93.5	76.3	65.9	56.1	46.2	38.5	21.3
1.70V/cell	336.9	268.8	193.2	125.2	94.5	76.7	67.5	58.1	47.5	38.4	21.2

Constant Power Discharge (Watts) at 20°C (68°F)

F.V/Time	15min	30min	1h	2h	3h	4h	5h	6h	8h	10h	20h
1.90V/cell	247.4	240.4	217.3	160.5	130.9	108.6	96.2	86.7	72.3	63.7	38.4
1.87V/cell	334.4	304.4	247.9	183.8	146.7	123.1	108.3	94.2	79.3	67.2	38.4
1.83V/cell	406.4	357.9	283.2	203.2	161.6	133.3	116.6	101.9	84.8	71.1	40.8
1.80V/cell	457.7	393.8	306.7	214.7	168.8	139.8	121.1	105.4	87.0	72.9	41.6
1.75V/cell	529.6	440.3	333.6	227.9	174.1	142.9	124.2	105.8	88.1	73.3	41.6
1.70V/cell	584.8	478.8	348.5	230.0	174.3	142.9	126.7	109.4	47.5	72.8	40.4

5 OPzS 350

Dimension

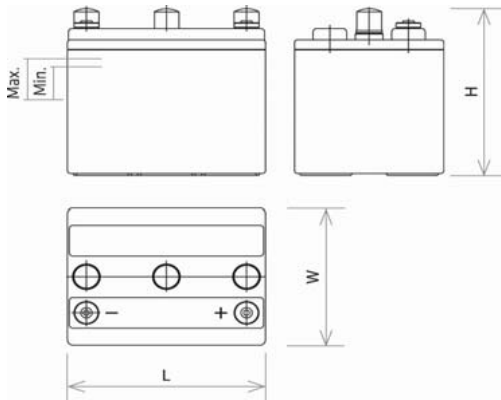

Voltage vs. % of discharge at Cx

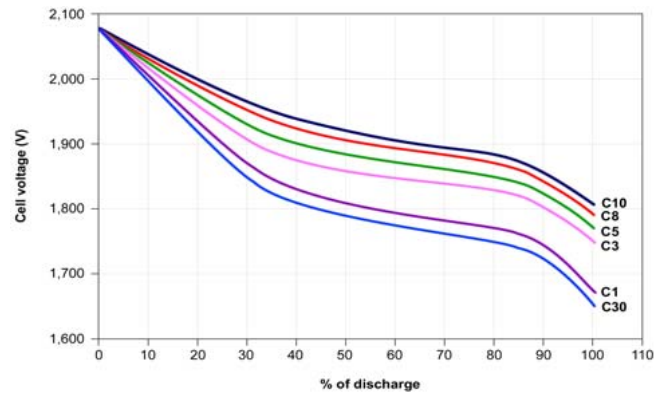

Lifetime in cycles vs. temperature at DOD

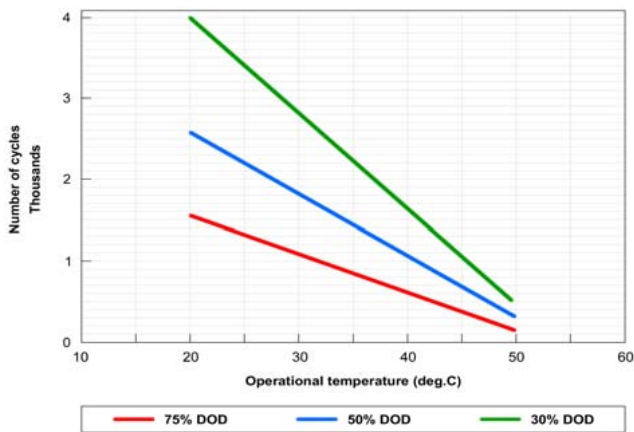

Float voltage as f (T)

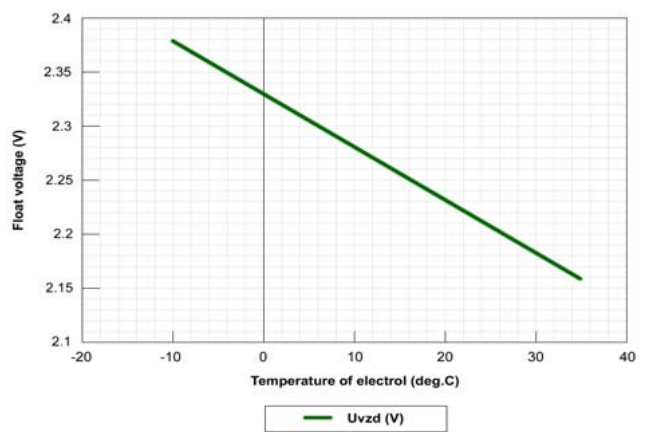

Gassing voltage as f (T)

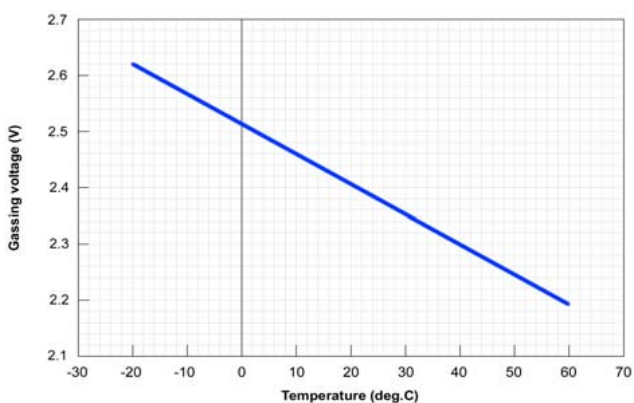

Charging of OPzS cells with IU charger

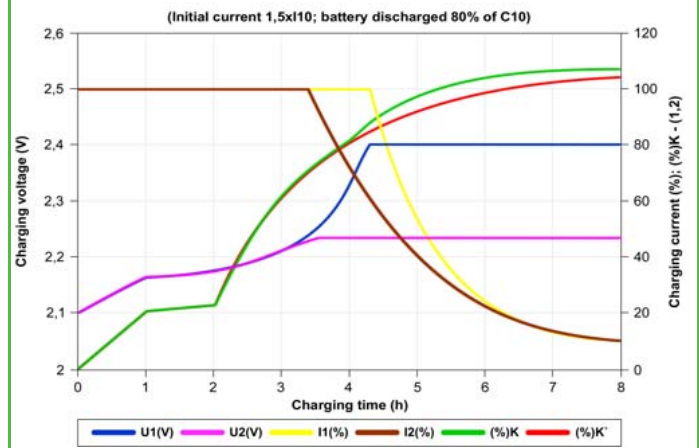

MH26866



ETL SEMKO

